

# FMV H-151E

## FIRŠT MIXING VALVES

3-way mixing valves H-151E with by-pass and pump connection with euronorm system

FIRŠT®



**FMV H-151E**

Valves are available in DN 25, with by-pass and pump connection and are rated PN10.

- FIRŠT FMV H-151E valves have the running nut for pump connection, the male connection to the manifold and the adjustable bypass on the way back and adjustable parallel dimension (125 - 90 mm).

### OPERATION

The FIRŠT FMV H-151E valves with by-pass and pump connection are intended to be used in heating and/or cooling systems, sanitary applications and distribution groups.

Valves are suitable for long-lasting operation because of special sealing construction. Small rotation torque of the valve minimizes possibility of valve blocking.

Valves are hand operated and can be additionally equipped with UNI series actuators.

### MAINTENANCE

Valves require no maintenance. The installation of suitable strainer is recommended.

### INSTALLATION POSITIONS

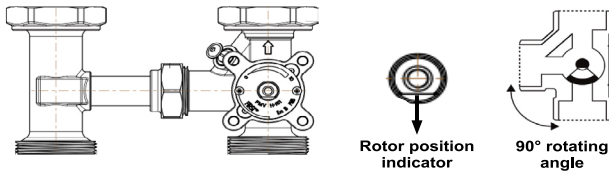

### EUONORM AXLE SYSTEM

Valve allows easy installation of actuators or upgrading valves with actuator. Euronorm axle is standard for most world manufacturers of valves and it is suitable for long-term operation at high torque.



### TECHNICAL DATA

Pressure class:	PN 10
Medium:	water, glycol < 50% water quality as per VDI 2035
Media temperature:	min. -10°C max. +110°C
Leakage ( $\Delta p=1$ bar):	max. 0,5% Kvs
Max. diff. pressure:	1 bar
Connections:	Rp internal thread (EN 10226-1) G external thread (ISO 228-1)

#### Material

Valve body:	Brass, CW617N
Shaft and rotor:	Brass, CW617N
Bushing:	PTFE
O-Rings:	EPDM,FKM

PED 97/ 23/ EC/ art 3.3

### EQUAL PERCENTAGE FLOW CHARACTERISTIC

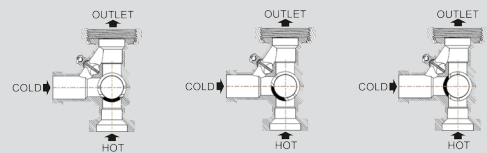
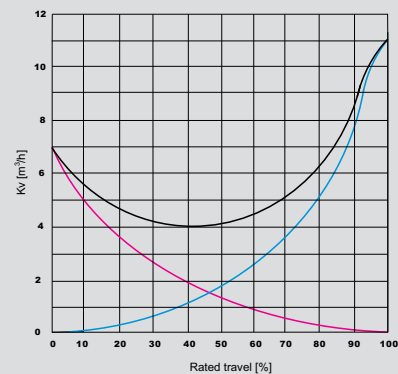

### SUITABLE ACTUATORS



- UNI 3P
- UNI MOD X
- UNI TEMP
- S11 3P
- S11 MOD X AC/DC
- S11-CT

FIRŠT®

**FIRŠT d.o.o.**  
Koroška cesta 56  
SI-3320 Velenje  
SLOVENIA

phone: +386 3 898 35 00  
fax: +386 3 898 35 35  
email: info@first.si  
web: www.first.si

**www.first.si**  
Let Firšt be your first choice.



# FMV H-151E

## FIRŠT MIXING VALVES

3-way mixing valves H-151E with by-pass and pump connection with euronorm system.

### FMV H-151E

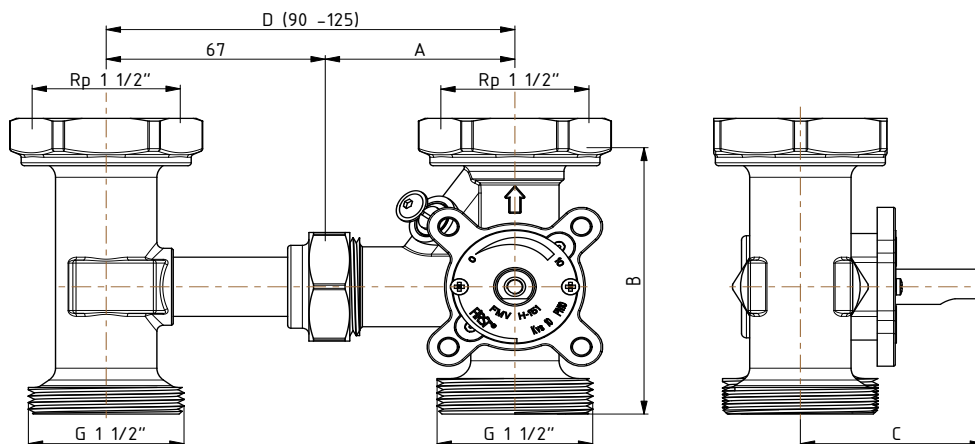

### FMV H-151E

Code	Type	DN	Kvs	Connection	A	B	C	Weight [kg]	Price (€)
41245	FMV H-151E	25	6	G1 1/2, G1, Rp 1 1/2	58	90	55	0,78	
41246	FMV H-151E	25	10	G1 1/2, G1, Rp 1 1/2	58	90	55	0,78	

### FMV H-151E complete set

Code	Type	Kvs	Connection	A	B	D	Weight [kg]	Price (€)
41247	FMV H-151E	25	6	G1 1/2, Rp 1 1/2	58	90	125-95	1,3
41248	FMV H-151E	25	10	G1 1/2, Rp 1 1/2	58	90	125-95	1,3

### Working way

Valves allow mixing between two fluids, warm and cold water, to get the desired temperature. The valve is right mounting with adjustable bypass. The bypass can be adjusted up to 50% of the total valve flow.

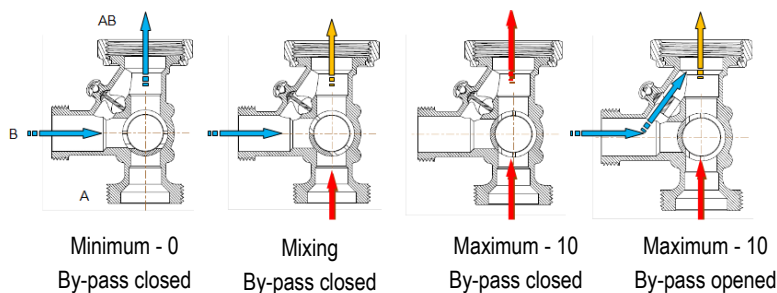

### Installation examples

